

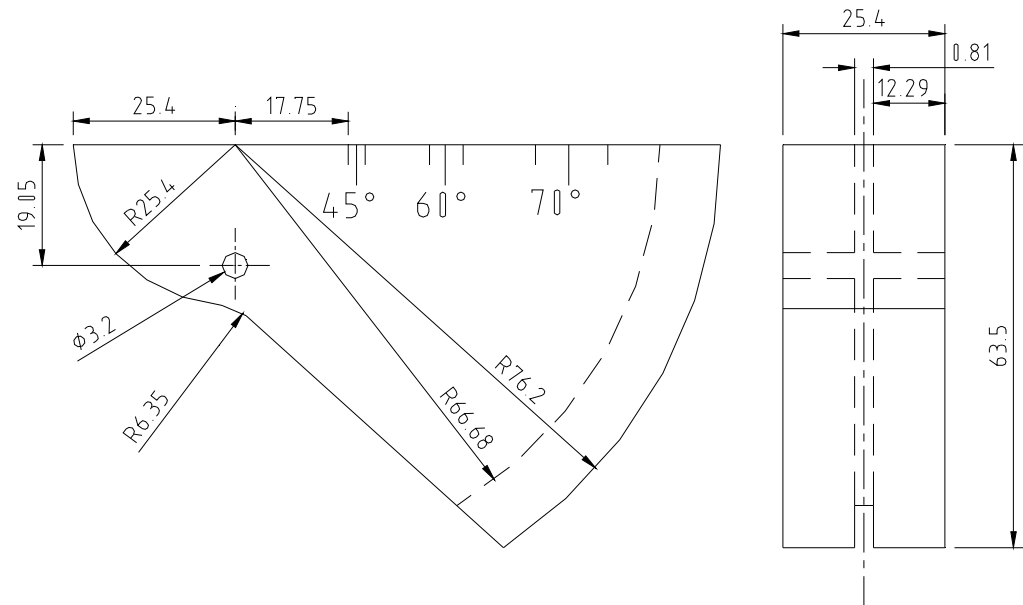



### 3:DSC Block



### 4: DC Block

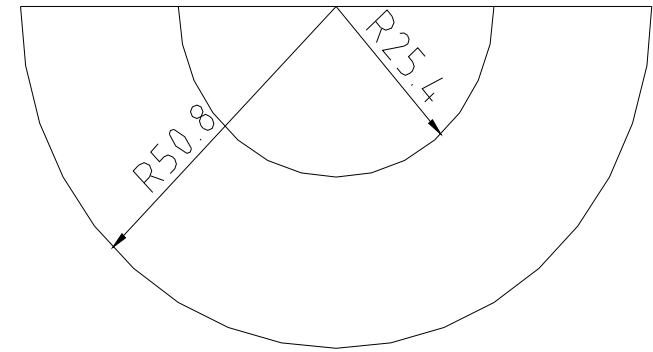
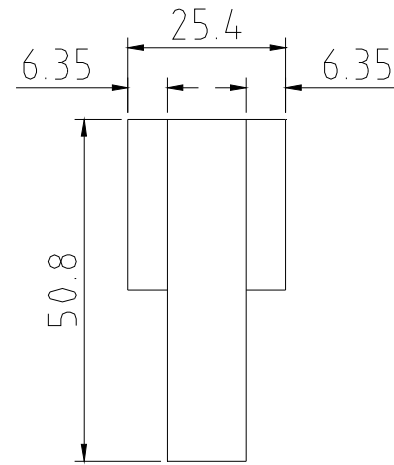

5: SC Block

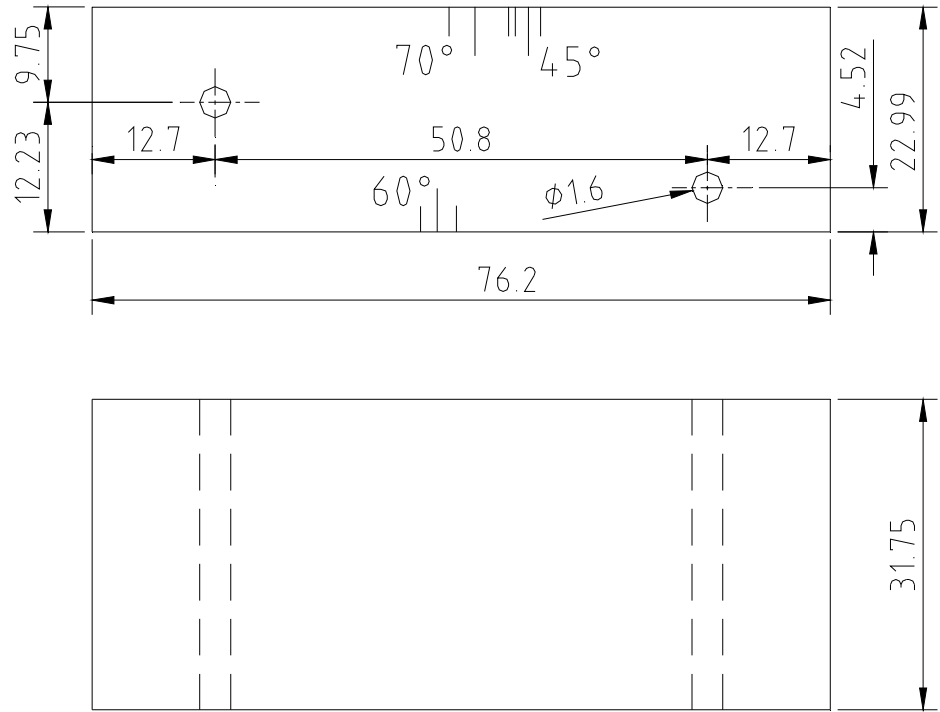
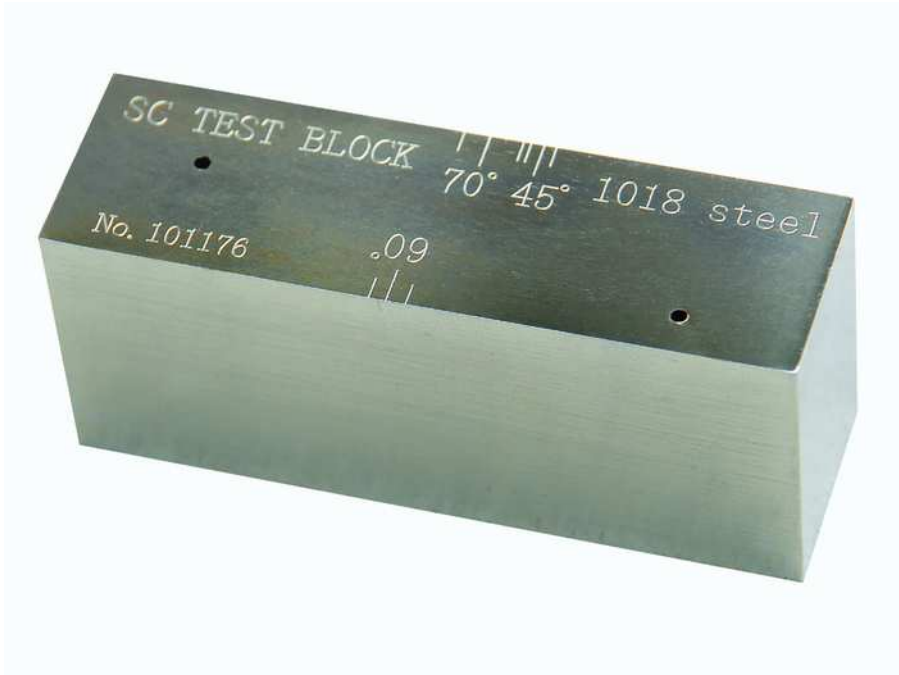

### 6: DS Block

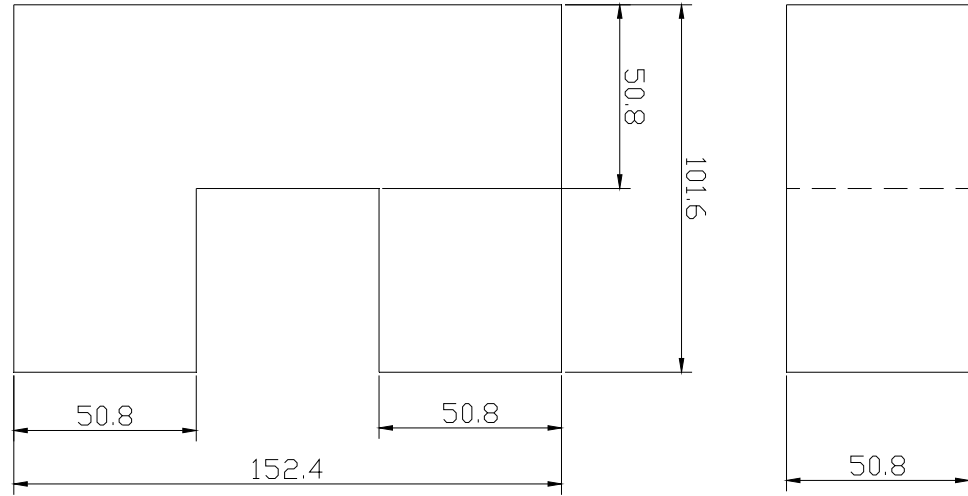
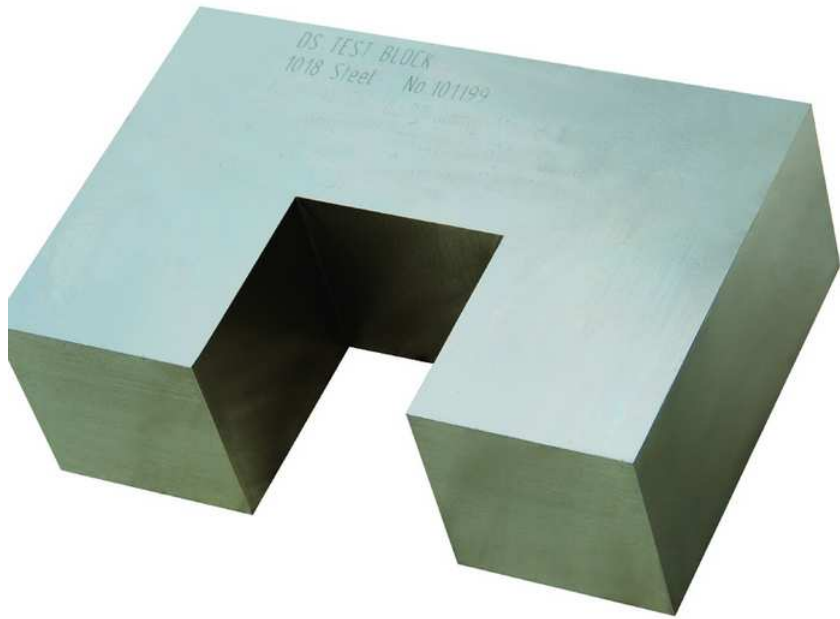

**7: RC Block**

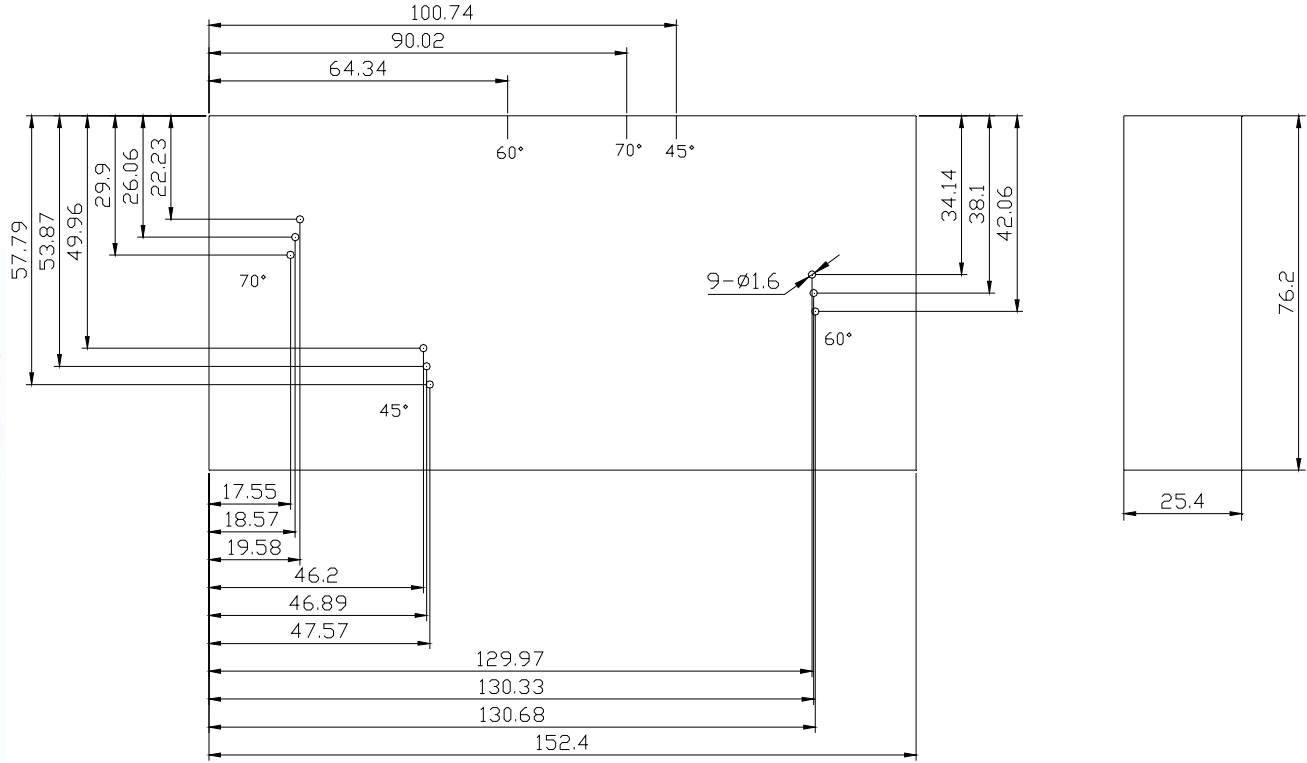
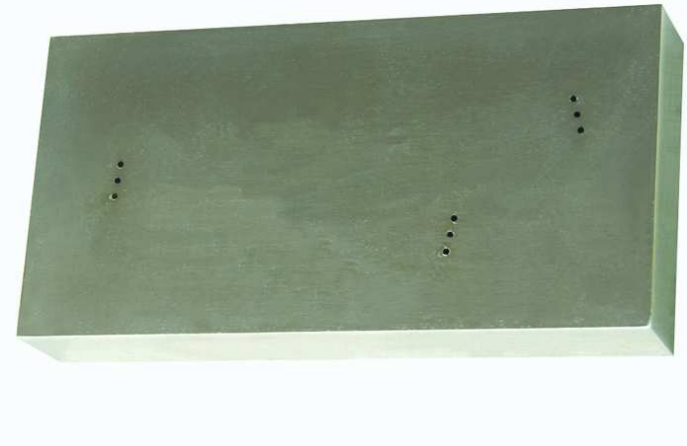

**8:A2 Block(The same to IIW 1)**

### 9: A2 Improved Block

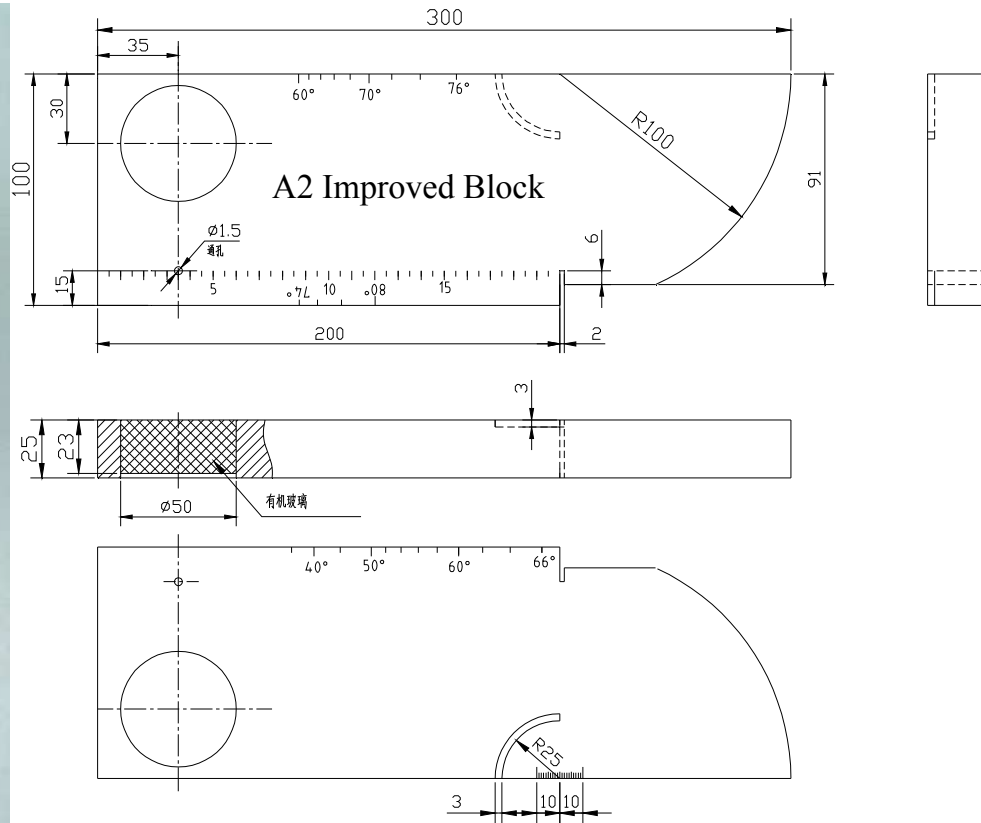



**10: A3 Block**

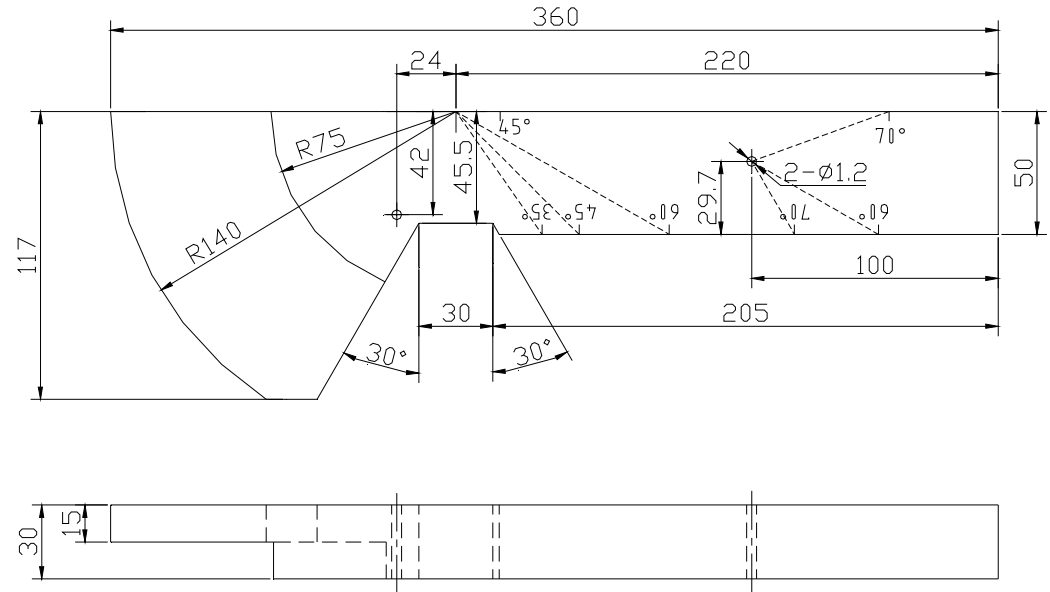

**11: A4 Block(The same to IIW2)**

## 12: A5(IOW) Block

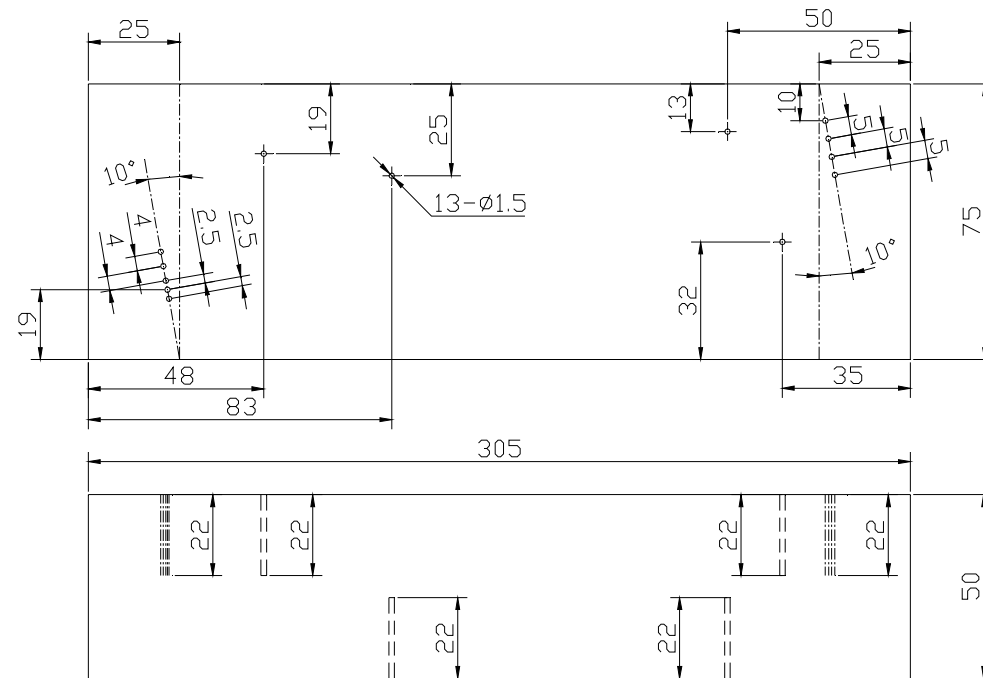

### 13: A6 Block

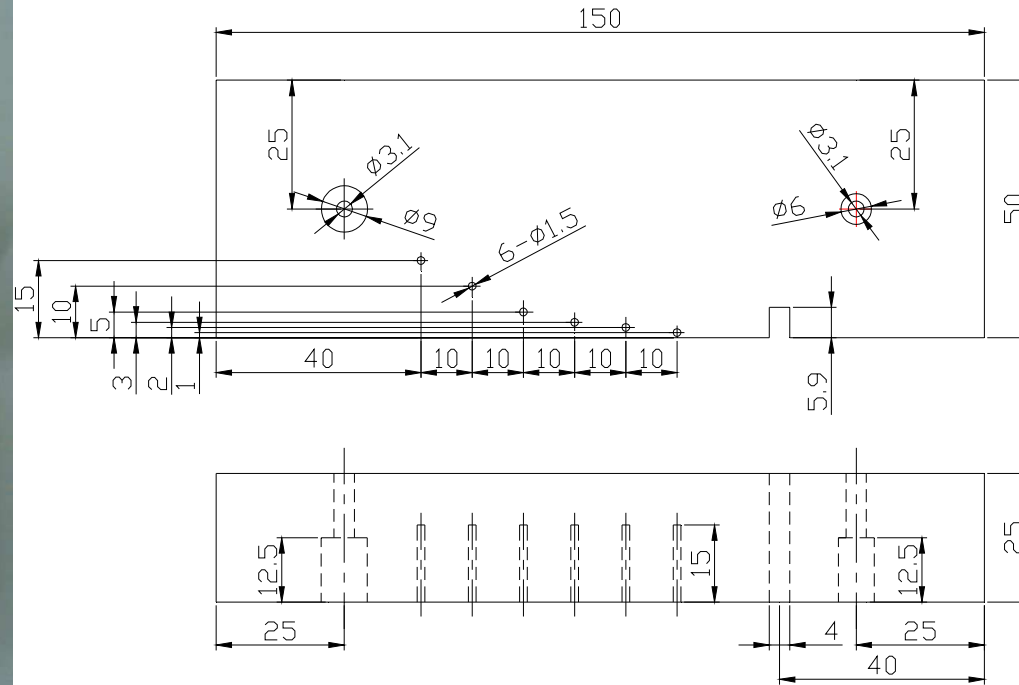

**14: A7 Block**

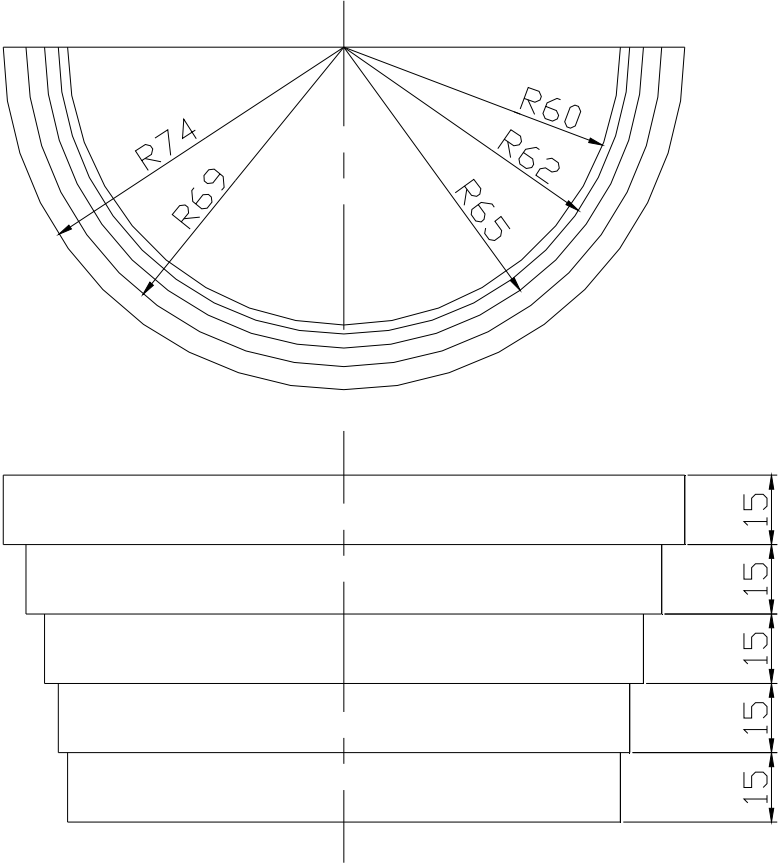



16:AUT Block



**West-East Gas Pipeline**



**Oil Pipeline Inspection**



**Offshore Oil Detected**



